



MATH SUMMER PACK
2020 - 2021
GRADE 9 TO 10

Name: _____

Set: _____

SECTION AMultiple Choice Questions**Select the correct answer from the following choices**

#		Working space
1)	$(2x^0y^0)^3$ is equal to: A $6x^3y^3$ B 8 C $8xy$ D 5	
2)	The simplest form of $\sqrt{40}$ is: A $\sqrt{4 \times 10}$ B $\sqrt{4} \cdot \sqrt{10}$ C $\sqrt{2} \cdot \sqrt{20}$ D $2\sqrt{10}$	
3)	$\sqrt{25 + 36}$ is the same as A $\sqrt{25} + \sqrt{36}$ B $5 + 6 = 11$ C $\sqrt{61}$ D 61	
4)	A calculator gives an answer of 5.42×10^7. This is equal to: A 0.540 000 0 B 00 000 542 C 542 000 00 D 542 000 0000	
5)	The solution of $(x - 3)^2 = 25$ is: A -8 B 9 or 5 C 8 or -2 D $x^2 - 6x + 14$	
6)	The complete factorisation of $12x^4 + 18x^3$ A $12x(x^3 + 6x^2)$ B $2x(6x^3 + 9x^2)$ C $6x^3(2x + 3)$ D $6x(2x^3 + 3x^2)$	
7)	The factors of $x^2 + 6x + 8$ are: A x B 2 and 4 C no common factors D $(x + 2)(x + 4)$	

Select the correct answer from the following choices:

#		Working space
8)	<p>Rationalise the denominator $\frac{3}{2\sqrt{3}}$</p> <p>A $\left(\frac{2\sqrt{3}}{2\sqrt{3}}\right)$</p> <p>B $\frac{6\sqrt{3}}{12}$</p> <p>C $\frac{12-6\sqrt{3}}{16-16\sqrt{3}+12}$</p> <p>D $\frac{9\sqrt{3}}{4}$</p>	
9)	<p>The point A(- 5 , - 8) is found in...</p> <p>A Quadrant I</p> <p>B Quadrant II</p> <p>C Quadrant III</p> <p>D Quadrant IV</p>	
10)	<p>A set of points are collinear if they...</p> <p>A form lines that intersect.</p> <p>B form a right-angled triangle.</p> <p>C fall on the same line.</p> <p>D are parallel to each other.</p>	
11)	<p>If we make y the subject of: $5x + 6y = 18$, the answer is:</p> <p>A $y = -\frac{5}{6}x + 12$</p> <p>B $6y = 5x + 18$</p> <p>C $6y = -5x + 18$</p> <p>D $y = -\frac{5}{6}x + 3$</p>	
12)	<p>An aeroplane flying from London to China covers a distance of 7100km in a time of 8 hours. What is its average speed?</p> <p>A 57600.4km/h</p> <p>B 680.6km/h</p> <p>C 887.5km/h</p> <p>D 680.5km/h</p>	
13)	<p>Solve the simultaneous equations :</p> <p>$x + y = 6$</p> <p>$x - y = 4$</p> <p>A $x = 6 , y = -4$</p> <p>B $x = 5 , y = 1$</p> <p>C $x = 5 , y = -1$</p> <p>D $x = 6 , y = 4$</p>	

Select the correct answer from the following choices:

#		Working space
14)	<p>Solve the simultaneous equations :</p> $x + 3y = 2$ $x + 2y = 1$ <p>A $x = -1, y = 1$ B $x = 0, y = 0$ C $x = 1, y = -1$ D $x = 0, y = 1$</p>	
15)	<p>A square has a perimeter of 12cm. The length of each side is:</p> <p>A 4 cm B 3 cm C 3 cm and 4 cm D 2 cm and 6 cm</p>	
16)	<p>A circle has a circumference of approximately 31.42m. Its radius is:</p> <p>A 9 m B 3.142 m C 10 m D 5 m</p>	
17)	<p>A right-angled triangle has a base of 4.7m and a perpendicular height of 5m.</p> <p>The area of the triangle is:</p> <p>A 12.3 m^2 B 10.2 m^2 C 11.8 m^2 D 11.7 m^2</p>	
18)	<p>A sector and a semi-circle will have equal areas if $\theta =$</p> <p>A 90° B 180° C 270° D 360°</p>	
19)	<p>A sector with angle 80° has a perimeter of 20.38 cm. Its radius is:</p> <p>A 3cm B 4cm C 5cm D 6cm</p>	

Select the correct answer from the following choices:

#		Working space
20)	<p>A cube has a volume of 125cm^3. The cube has sides of length:</p> <p>A 12.5cm</p> <p>B 0.125cm</p> <p>C 25cm</p> <p>D 5cm</p>	

SECTION B

True and False

State whether the following statements are True or False. Correct any false statement.

Statement	True / False	Correct if statement is false
1) The graph of $y = -x^2 + 2x + 1$ is linear		
2) The points (1, 3) and (5, 3) have a distance of 5 units apart.		
3) Quadrant IV of the Cartesian plane consists of only negative values.		
4) 100 can be written as: $2^2 \times 5^2$		
5) $-5^2 = 25$		
6) $(4 - \sqrt{2})^2 = -4\sqrt{2} + 18$		
7) $(3x)(4x)(y) = 12x^2y$		
8) $(x - 5)^2 = x^2 + 25$		

State whether the following statements are True or False. Correct any false statement.

Statement	True / False	Correct if statement is false
9) The HCF of $18x^3$ and $12x^2$ is: $6x^2$		
10) $y = 2x + 5$ has a gradient of 5.		
11) The equation $x - 5y = -1$ multiplied by 2 is equal to $2x - 10y = -2$		
12) If we make r the subject of: $F = \frac{Ar^2}{d^2}$ The answer is: $r = \sqrt{\frac{Fd^2}{A}}$		
13) It is possible to have two different shaped boxes that have the same volume.		
14) Two squares are combined to make a rectangle of area of 18cm^2 . The side lengths of the squares is 3cm.		
15) A square has a perimeter and area both equal to 16. The length of its sides is 4.		
16) A sphere with radius 9cm has an area of 268cm^2		
17) Two circles can have the same area only if their radii are equal.		
18) For squares, their perimeter and area are always the same.		

SECTION C**CHAPTER 6****Simplify the following using laws of exponents:**

a) $\frac{5^2 \times 2^2 \times 3^0}{5^2}$

b) $(3a)^{-3}$

c) $(2p^2q^3)^3$

Write the following numbers in standard form:

a) 53500

b) 0.00096

c) 2999

Simplify the surds below:

a) $(\sqrt{6})^2$

b) $(\sqrt[9]{-7})^9$

c) $\left(\frac{1}{\sqrt{13}}\right)^2$

d) $(4\sqrt{2})^3$

e) $2\sqrt{5} - 7\sqrt{3} + 2\sqrt{5} - 10\sqrt{3}$

f) $\sqrt{5} \times \sqrt{3}$

g) $3 \times 5\sqrt{2}$	h) $-5\sqrt{3} \times (\sqrt{2})^3$	i) $3\sqrt{2} \times 4\sqrt{2}$
j) $3\sqrt{2} + 4\sqrt{2}$	k) $3\sqrt{5} - 3\sqrt{5}$	l) $5(2\sqrt{6} + 4\sqrt{3})$
m) $\frac{\sqrt{20}}{\sqrt{5}}$	n) $\sqrt{8}$	o) $\sqrt{120}$

EXTENSION:

Find a, b, c, d and e such that:

$$(2\sqrt{3} + 3\sqrt{2}) \times (\sqrt{3} - \sqrt{2})^{-1} = \frac{a\sqrt{b} + c\sqrt{d}}{e}$$

Simplify the question below:

$$(a\sqrt{3} - \sqrt{2})(\sqrt{3} + \sqrt{2})$$

Simplify the question below:

$$(a\sqrt{b} - c\sqrt{d}) \times (a\sqrt{b} + c\sqrt{d})$$

Find b and c such that:

$$\frac{a\sqrt{3} - \sqrt{2}}{a\sqrt{3} + \sqrt{2}} = a^{b\sqrt{c}}$$

Danny's dad wants to share his 12 BMWs and 18 Jaguars amongst his sons, equally. Talkative Tommy thinks Danny has 6 brothers. Is he correct? Explain your answer.

Anup has 96 gold medals, 48 silver medals and 20 cups that he would like to leave in his will, equally amongst his grandchildren. What is the maximum number of grandchildren that he could have (he hopes)?

You are given the HCF and LCM of two numbers. What might the two numbers be if the following is true (give two answers for each)?

a) HCF = 5, LCM = 60

b) HCF = 12, LCM = 84

c) HCF = 24, LCM = 720

I am a multiple of 21 and 35. I have four digits. What is the smallest number I could be?

Rationalise the denominator:

a) $\frac{3}{\sqrt{3}}$

b) $\frac{x+4}{\sqrt{2}}$

c) $\frac{5}{2-3\sqrt{2}}$

d) $\frac{3-4\sqrt{5}}{4\sqrt{3}}$

CHAPTER 1

Expand and Simplify the following:

a) $-(3a-3)$

b) $5a+3(2-9a)$

c) $6(a+12)-4(4a-5)$

d) $2x(5-4x+x^2)$

e) $(4-3a)(2a+6)$

f) $(a+4)^2$

g) $(3 - 6x)^2$	h) $(5a^2 - 5)(5a^2 + 5)$	i) $(2a - 3b)^2$
j) $a(a + 3)(a - 6)$		k) $(x - 3)(x^2 + 5x + 4)$
l) $(a - 7)(a + 3)(a + 1)$	m) $(3x - 1)(3x + 1) + (x + 2)^2$	

Find the highest common factor (HCF) of the following:

a) $6x$ and $12x$	b) $3x^3$, $6x^6y$ and $18x^{18}$	c) $2(x - 1)$ and $(x - 4)(x - 1)^2$
--------------------------	---	---

Fully Factorise the following:

a) $-12xy - 36xy^2$	b) $3x^4 - 6x^3 - 90x^2$	c) $3a^2 + 12a + 18$
----------------------------	---------------------------------	-----------------------------

d) $a(x + 2) + b(x + 2)$	e) $a(x - 2) + 3(x - 2)(x + 4)$	f) $x^2 - 9$
g) $2x^2 - 32$	h) $25x^2 - (2y + 3)^2$	i) $(2x + 5)^2 - (x + 3)^2$
j) $x^2 + 9x + 14$	k) $x^2 + 9x - 36$	l) $x^2 - 11x + 24$
m) $x^2 - 16x - 36$	n) $5x^2 + 40x + 80$	o) $6x^2 + 11x + 3$
p) $-x^2 - 15x - 36$	q) $6x^2 + 3x - 24x - 12$	r) $12x^2 - 8x + 3x - 2$

CHAPTER 21**Solve for x in the following equations:**

a) $3x^2 - 4 = 20$

b) $(x + 5)^2 = 4$

c) $4x^2 - 16 = 24$

d) $3x^2 = -27$

e) $2(4y - 2)^2 = 32$

f) $5x(x + 3) = -(x + 3)$

g) $\frac{x}{x + 2} = \frac{2}{2x + 4}$

h) $x(x - 6) = x^2 + 36$

i) $\frac{2x}{x} = \frac{3x-1}{x-2}$

j) $(x-2)^2 + 3(x-2) - 4 = 0$

EXTENSION:

Solve for x

$$(\sqrt{3}x - 1)^2 + 2(\sqrt{3}x - 1) - 2 = 0$$

Find a , b and c such that:

$$(2x - 3)^{-2} = \frac{1}{ax^2 + bx + c}$$

If the area of the triangle below is 12cm^2 , find the value of x .

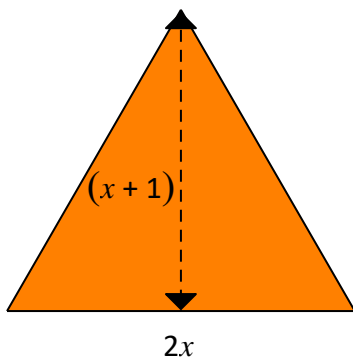

If the area of the rectangle below is 45cm^2 , find the value of x and hence find the perimeter.

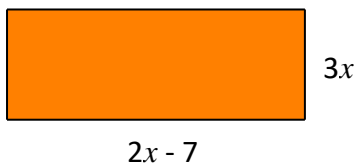

Two square rooms have a total floor area of 208 square metres. One room is 4m longer than the other. Find the floor dimensions of each room.

The area of a rectangle is 6cm^2 . If the length is 1 metre longer than the width, find the perimeter of the rectangle.

A rectangular room is 4m wider than it is high and 8m longer than it is wide. The total area of the walls is 512m^2 . Find the width of the room.

Solve for x , giving exact answers AND then giving answers correct to 2 decimal places.

$$x = \frac{-b \pm \sqrt{b^2 - 4ac}}{2a}$$

a) $x^2 + 5x = 6$

b) $x^2 + 3x - 4 = 0$

c) $3x^2 + 5x - 2 = 0$

Show that the following quadratic equation has no real solutions:

a) $x^2 + 3x + 2 = 0$

CHAPTER 12

Plot and label the following points on the coordinate plane below:

- A (2, 3)
- B (2, 0)
- C (-1, 3)
- D (-2, -1)
- E (-2, -2)
- F (-4, -3)

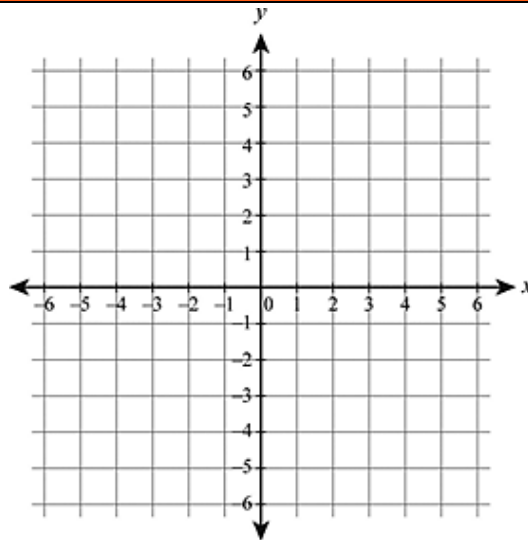

Find the distance between the following sets of points:

a) A (-2, -1) and B (1, 3)

b) A (2, 3) and B (2, 0)

If necessary, use Pythagoras' theorem to find the distance between:

a) A and C

b) A and E

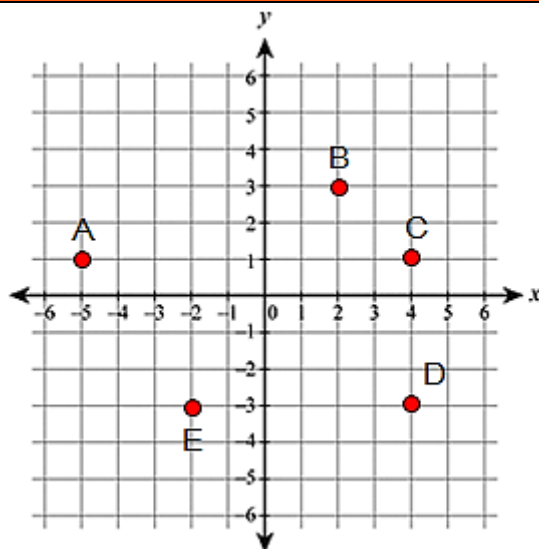

Classify triangle PQR as either equilateral, isosceles, or scalene.

P (3 , 2) , Q (1 , 0) , and R (-1 , 2)

Use the distance formula to check if the triangle ABC is a right-angled triangle.

A (1 , 0) , B (-2 , 0) , and C (-2 , 4)

Find m.

a) A (-5, 0) and B (1, m) are 9 units apart. **Find m.**

b) A (-4, -1) and B (1, m) are $\sqrt{34}$ units apart. **Find m.**

Find the coordinates of the midpoint between the points below:

$$\text{Midpoint} = \left(\frac{x_1 + x_2}{2}, \frac{y_1 + y_2}{2} \right)$$

A (8, -2) and B (2, 4)

Given are the midpoint and coordinates of A. Find the coordinates of B.

Midpoint (3, 1)

A (-1, 4) Find B (x_2, y_2)

State the gradient of each line below:

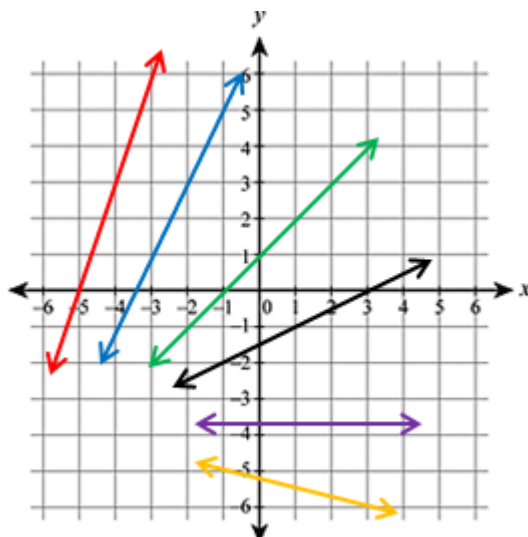

Red:

Blue:

Green:

Black:

Purple:

Yellow:

Complete the statement:

- a) A vertical line has a gradient of _____
- b) A horizontal line has a gradient of _____

Find the gradient of each line with the given points.

$$\text{Gradient} = \frac{y_2 - y_1}{x_2 - x_1}$$

a) A (13, 1) and B (6, 15)

b) A (-8, -5) and B (13, -6)

Find k if the line joining A (5, 0) and B (2, k) is: parallel to a line with gradient $\frac{1}{2}$

Find k if the line joining A (5, 0) and B (2, k) is: perpendicular to a line with gradient $-\frac{1}{4}$

Show that the following sets of points are collinear: A (4, 1), B (7, 7) and C (8, 9)

Find b given that A (-3, 5), B (b , 3) and C (6, -1) are collinear.

CHAPTER 14**Draw the graph of the straight line: $y = 3x + 3$**

Show all working:

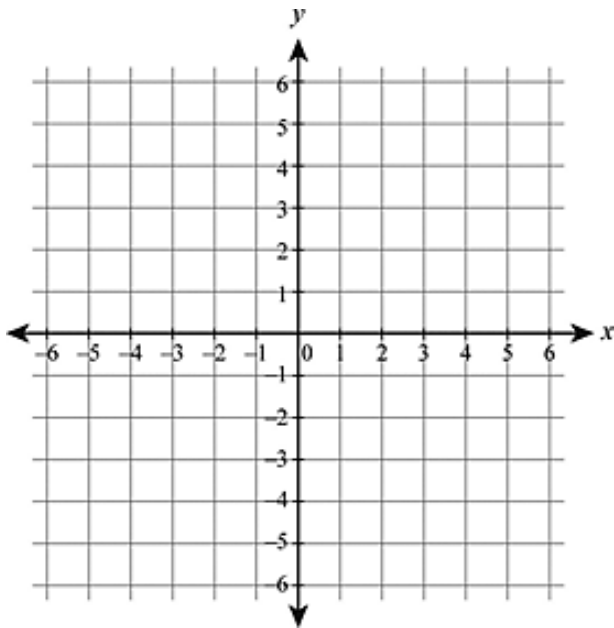

x	y
-2	
-1	
0	
1	
2	

Draw the graph of the quadratic function: $y = x^2 + 2x + 1$

Show all working:

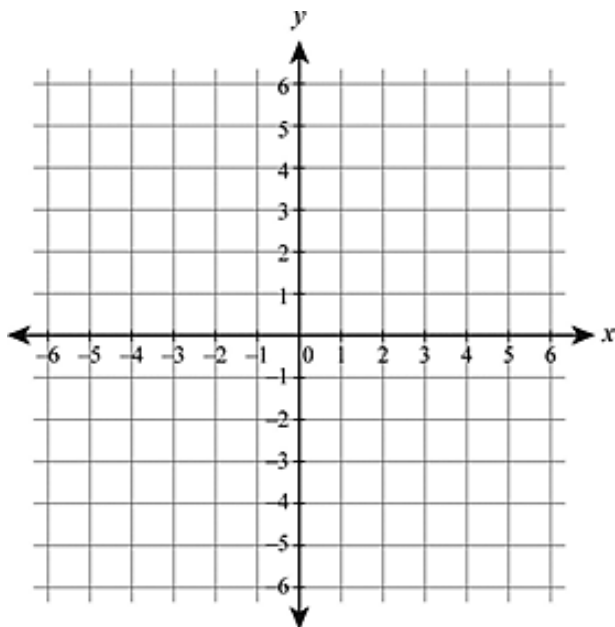

x	y
-3	
-2	
-1	
0	
1	

Draw the graph of the quadratic function: $y = -x^2 - 2x + 3$

Show all working:

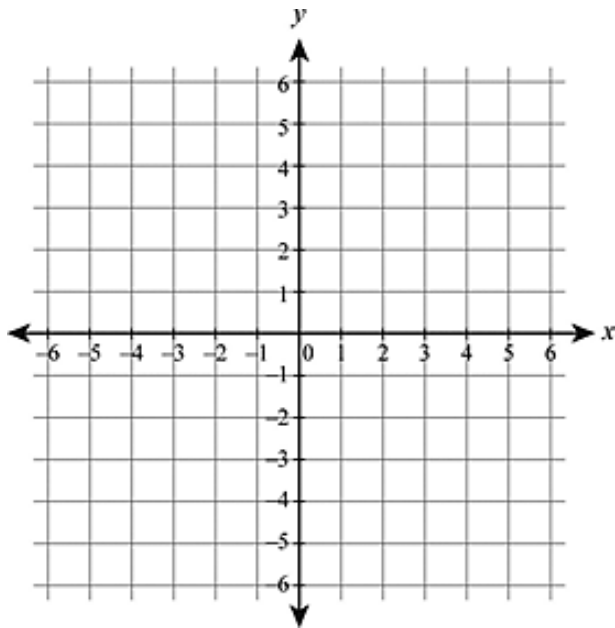

x	y
-4	
-3	
-2	
-1	
0	
1	
2	

What is the gradient of the straight line $6x - 9y = 3$?

Find the equation of the straight line below:

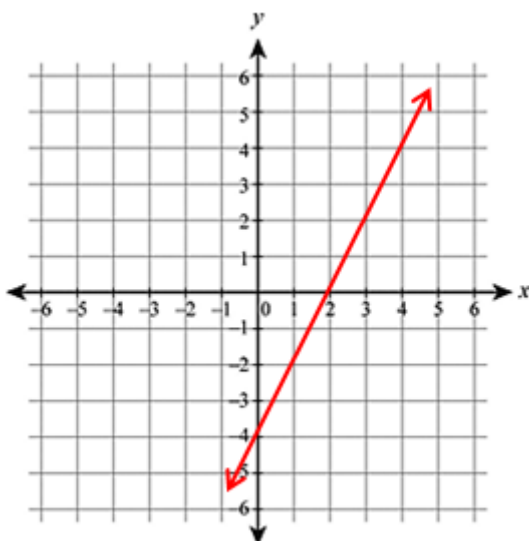

Convert $x + 3y = 4$ into gradient-intercept form.

Convert $10x + 5y = 15$ into gradient-intercept form.

Convert $y = 3x - 4$ into general form.

Convert $y = \frac{1}{2}x + 3$ into general form.

Find a given that $(a, 5)$ lies on $y = 2x - 8$

Find in general form, the equation of the straight line below:

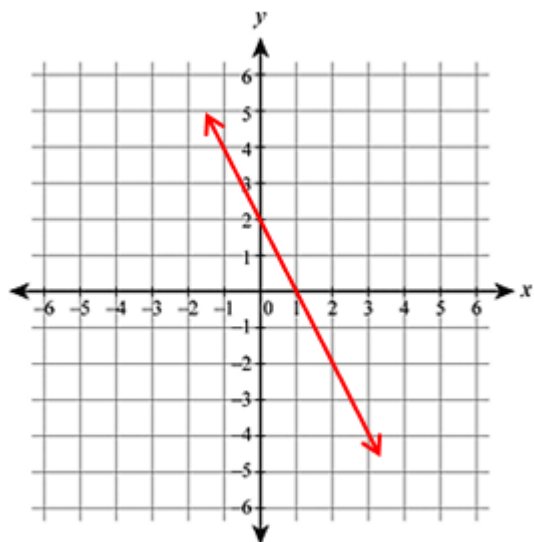

Find in general form, the equation of a line with gradient 3 and y-intercept of 6.

Find the equation of a line with gradient -1 and passes through point $(1, 2)$.

Find the equation of a line with gradient $\frac{1}{2}$ and passes through point $(5, 2)$.

CHAPTER 7

Given the formula: $s = \frac{d}{t}$ where **s** is average speed, **d** is distance travelled and **t** is time taken.

a) A motorcycle travels at an average speed (**s**) of 82km/h for a time (**t**) of 2.4 hours. Find the distance (**d**) travelled by the motorcycle during this time. Provide your answer in km.

b) An aeroplane flies at an average speed (**s**) of 875km/h over the Atlantic ocean. If the distance (**d**) covered was 1250km, calculate the time (**t**) taken for this journey. Provide your answer in hours.

Rearrange the given formula: $a - b = c + de - f^2$ in each question that follows:

a) Make **c** the subject of the formula.

b) Make **e** the subject of the formula.

The equation of a straight line is $7x + 6y = 12$. Rearrange the formula into the form $y = mx + c$

Find the simultaneous solution to the pairs of equations given:

a) $y = x + 4$
 $y = 4x - 3$

b) $x + y = 6$
 $3x + 4y = 12$

c) $x = 10 - 5y$
 $5x - 5y = 2$

Find the simultaneous solution to the pairs of equations given using elimination:

a) $5x - 2y = 3$
 $3x + 2y = 5$

b) $3x - 2y = 5$
 $5x - 3y = 8$

c) $8x - 6y = 2$
 $4x + 10y = 14$

Solve the following problems by applying a method of simultaneous equations

- a) At a shop, 6 chairs and 2 tables cost \$2000. At the same shop, 3 chairs and 3 tables costs \$1800. Calculate the cost of each chair and table.

b) The average of two numbers is 50 and their difference is 20. What are the two numbers?

c) The average of two numbers is 11. If one of the numbers is doubled and the other is tripled, their average increases to 28.5. Find the two numbers.

EXTENSION:

Make x the subject of $3x + 2y = r - kx$

Make m the subject of $4m - 3n = rn - pm$

Make t the subject of $k = \frac{t+2}{t-5}$

Make x the subject of $\frac{1}{x} + \frac{1}{y} = \frac{1}{z}$

CHAPTER 9

Find the perimeter of the following shapes:

a)

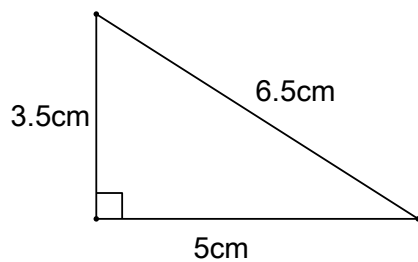

b)

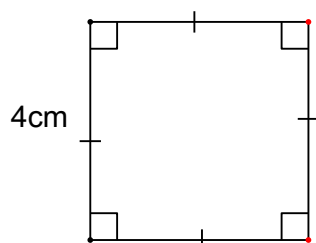

c)

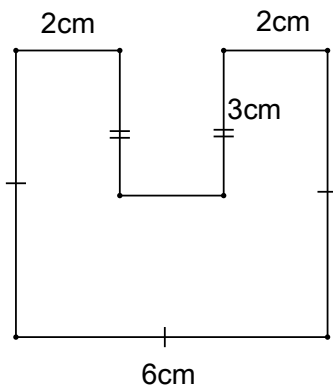

Find the area of the rectangle below:

Area = length \times width

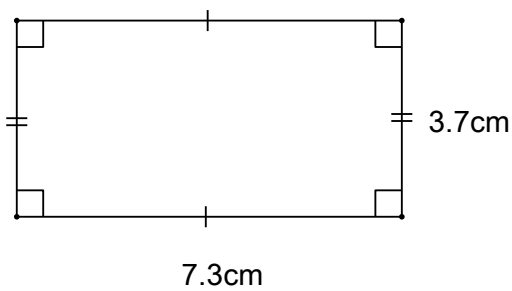

Find the area of the triangles below:

Area = $\frac{1}{2} \times$ base \times height

a)

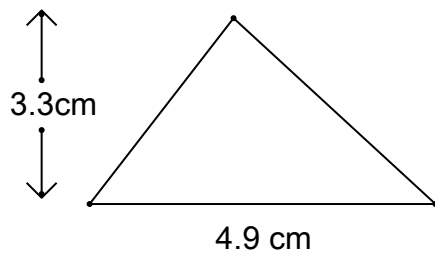

b)

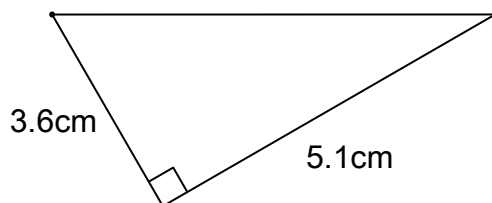

The area of the triangle below is 9cm^2 . Find the height.

$$\text{Area} = \frac{1}{2} \times \text{base} \times \text{height}$$

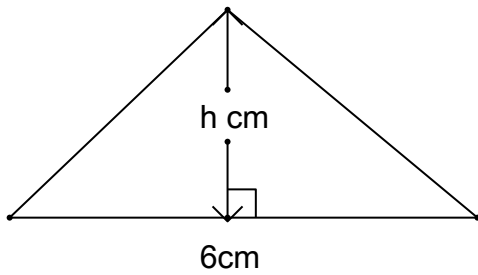

The area of the parallelogram below is 42cm^2 . Find the height.

$$\text{Area} = \text{base} \times \text{height}$$

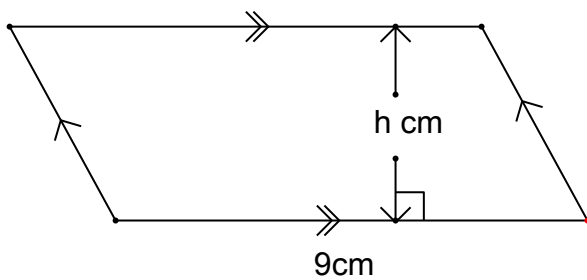

Find the area of the trapezium below:

$$\text{Area} = \left(\frac{a+b}{2}\right) \times \text{height}$$

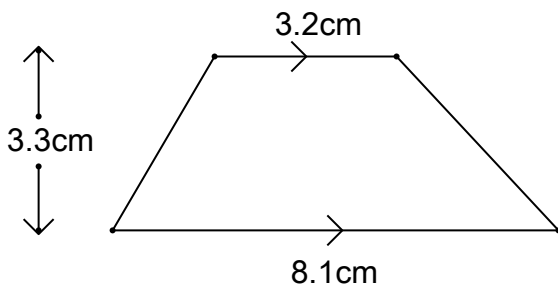

The area of the trapezium below is 72.22cm^2 . Find the height.

$$\text{Area} = \left(\frac{a+b}{2}\right) \times \text{height}$$

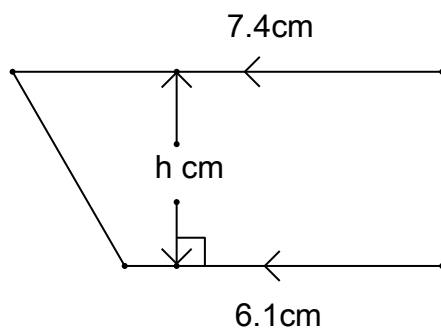

Find the area of the red shaded part of the rectangle below:

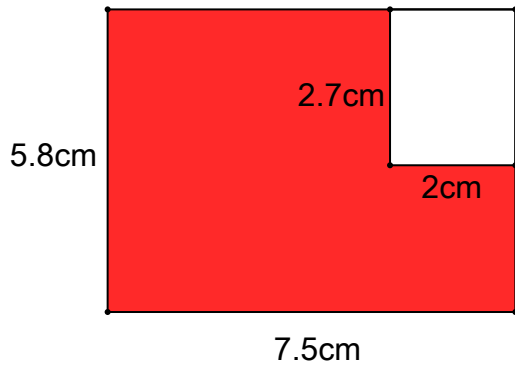

Find the area of the red shaded part of the triangle below:

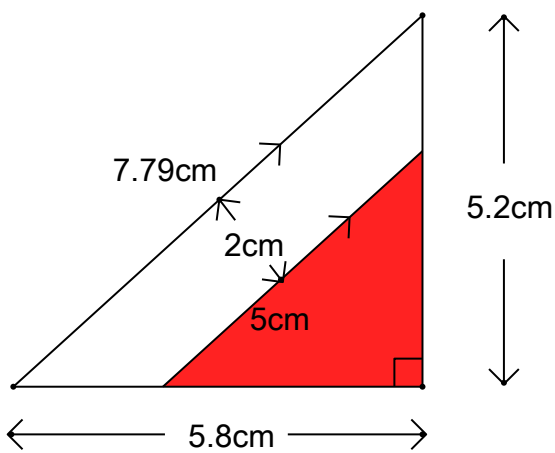

Find the perimeter of the shapes below:

Circumference = $2\pi r$

a)

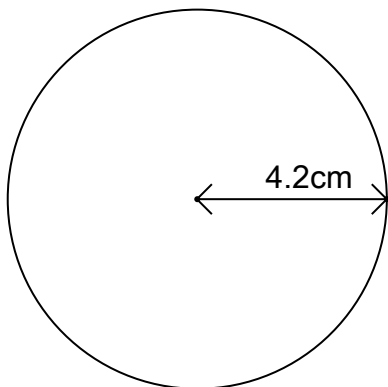

b)

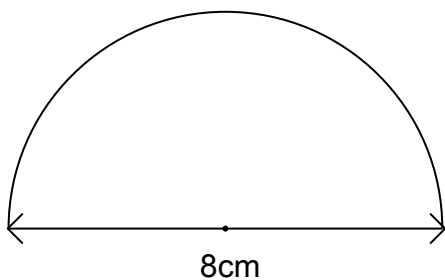

Find the arc length of the sectors below:

$$\text{Arc length} = \frac{\theta}{360^\circ} \times 2\pi r$$

a)

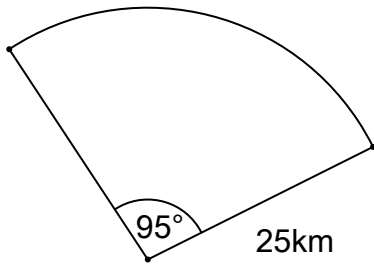

b)

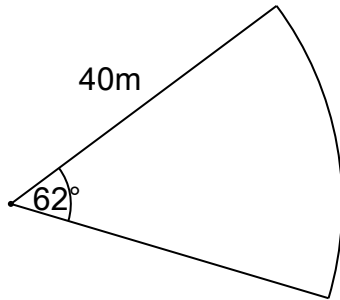

Find the perimeter of the sector below:

$$\text{Perimeter} = 2r + \left(\frac{\theta}{360^\circ} \times 2\pi r \right)$$

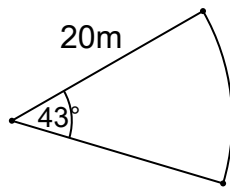

Find the area of the shapes below:

$$\text{Area} = \pi r^2$$

a)

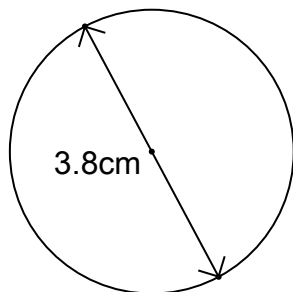

b)

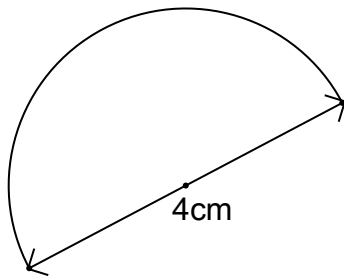

Find the area of the sector below:

$$\text{Area} = \frac{\theta}{360^\circ} \times \pi r^2$$

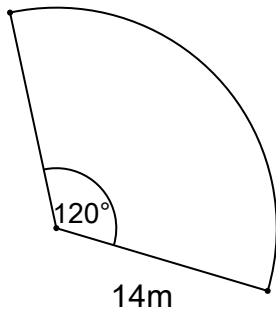

The circle below has an area of 78.54cm^2 . Find each value indicated below:

$$\text{Area} = \pi r^2$$

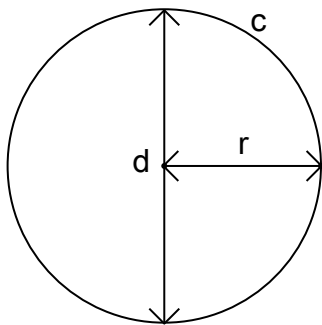

The sector below has an area of 15.36cm^2 and radius of 4cm . Find the value of θ .

$$\text{Area} = \frac{\theta}{360^\circ} \times \pi r^2$$

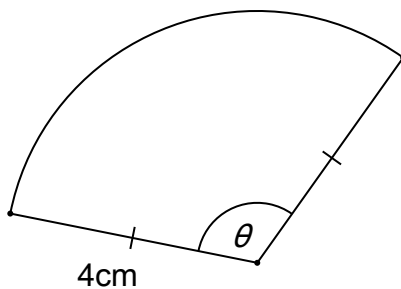

Find the area of each shape below:

a)

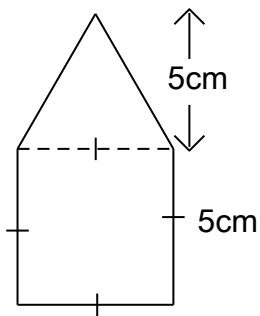

b)

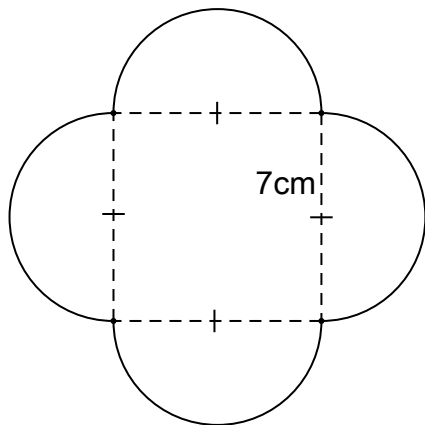

c)

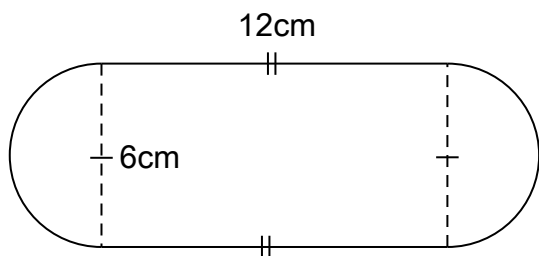

Given a rectangle with length $L = 2x - 3$ cm and width $W = 3x - 4$ cm.

a) Find the Perimeter P of the rectangle in terms of the variable x .

b) Find the area A of the rectangle in terms of the variable x .

c) Find the value of x such that the perimeter P of the rectangle equals to 16 cm.

d) Find the values of x such that the area A of the rectangle equals to 40 cm^2

CHAPTER 11

Find the surface area of the objects below:

a)

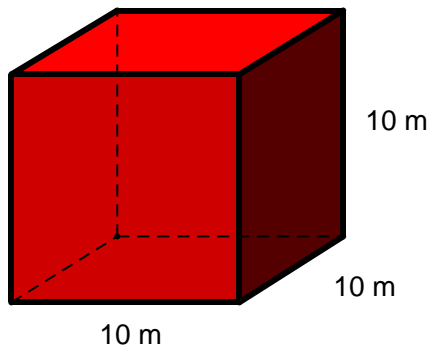

b)

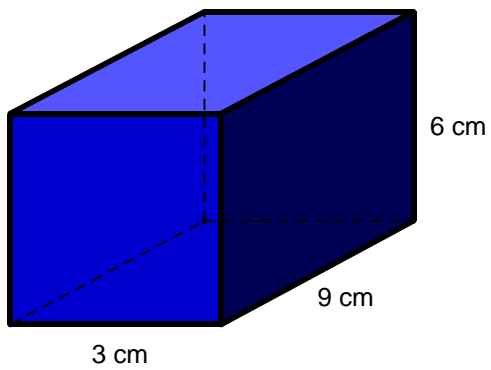

c)

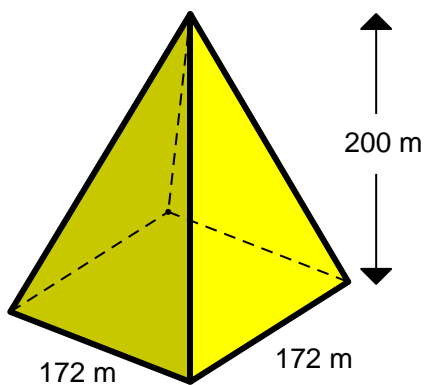

d)

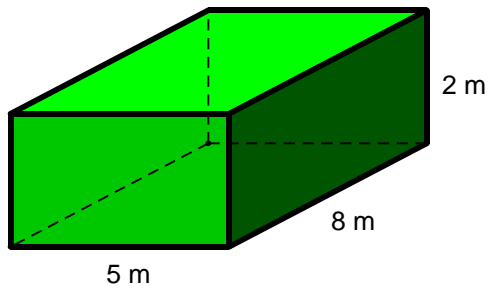

e)

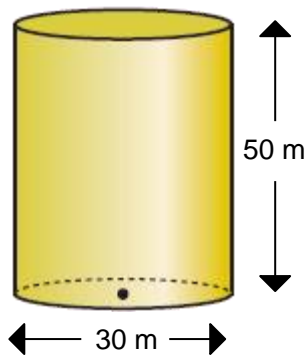

Find a formula for the surface area of:

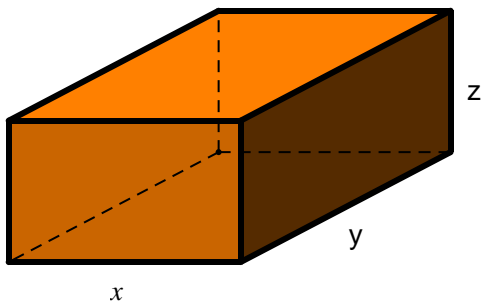

Convert 400 mm^3 to cm^3

Convert 57000 cm^3 to m^3

Find the volume of the cubes below:

Volume = length \times length \times depth

a)

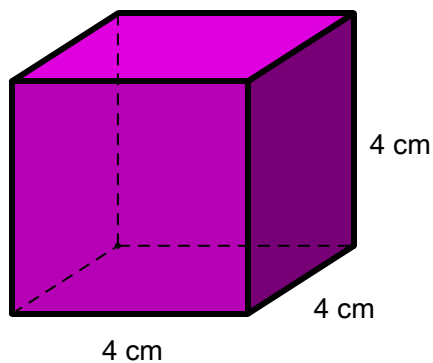

b)

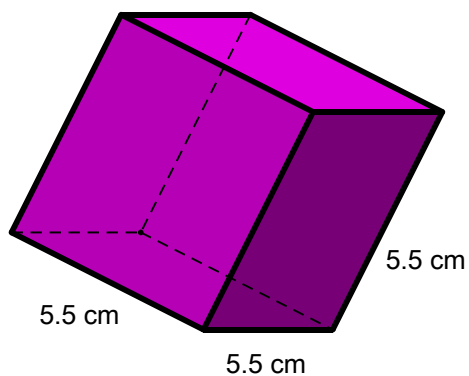

Find the volume of the rectangular prisms below:

Volume = length \times width \times depth

a)

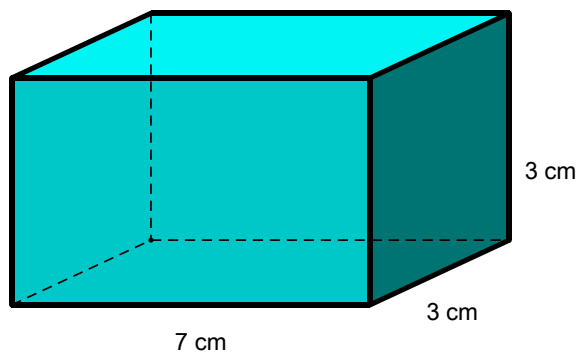

b)

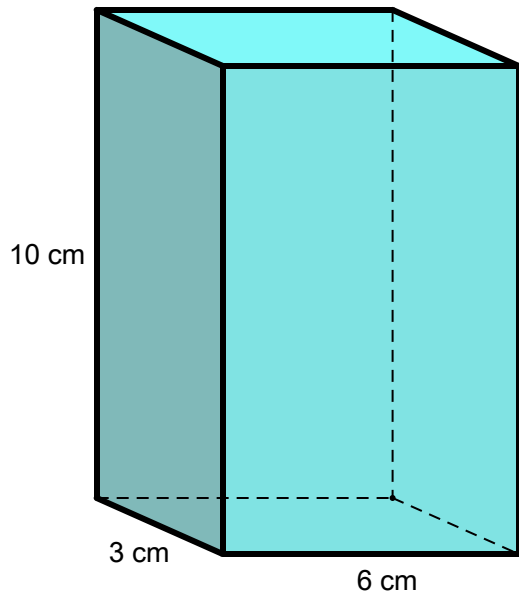

A cube has a volume of 575cm^3 . What is the measurement of each of its sides?

Find the volume of the triangular prism below:

$$\text{Volume} = \frac{1}{2} \times \text{base} \times \text{height} \times \text{depth}$$

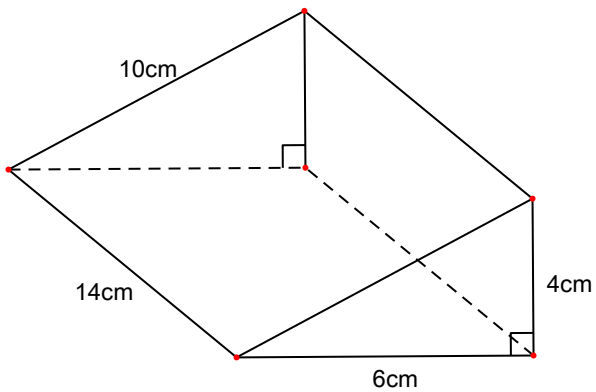

Find the volume of the cylinder below:

$$\text{Volume} = \pi \times r^2 \times \text{depth}$$

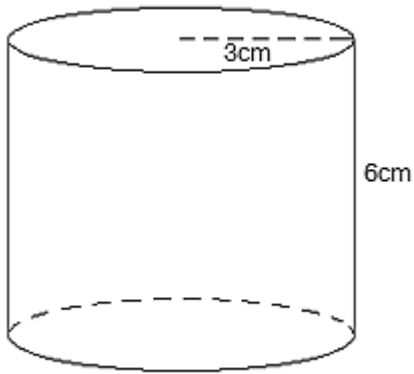

Find the volume of the sphere below:

$$\text{Volume} = \frac{4}{3} \pi \times r^3$$

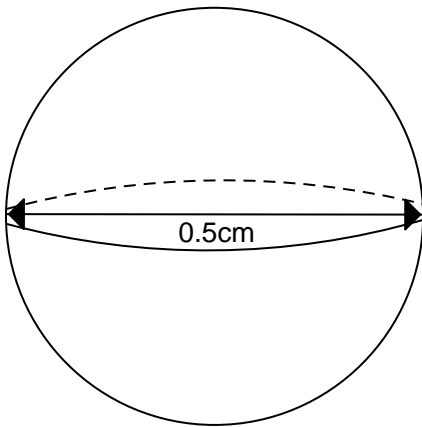

Find the volume of the hemisphere below:

$$\text{Volume} = \frac{2}{3} \pi \times r^3$$

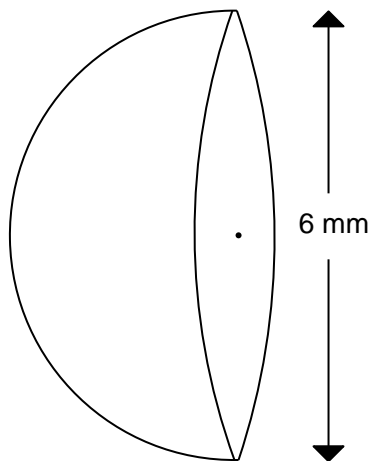

A Tennis ball has a diameter of 18cm. Find its volume.

What is the radius of a basketball if it has a volume of 603.168 cm^3 ?

EXTENSION:

Calculate the surface area of the solid below:

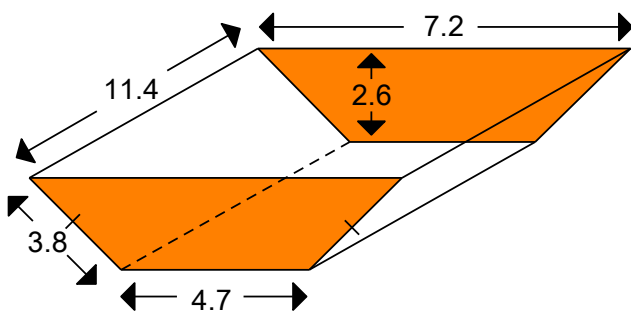

Calculate the surface area of the solid below:

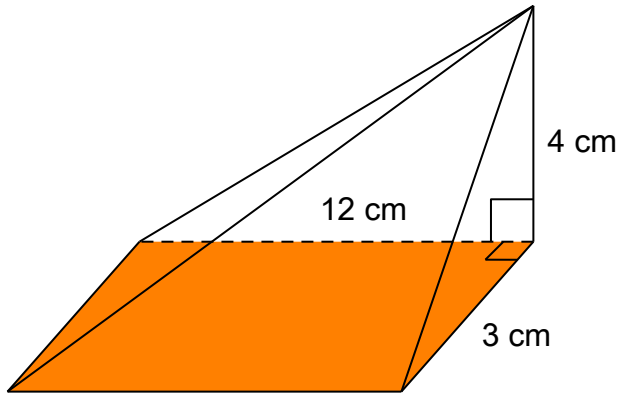

The volume of an isosceles triangular prism with base 12m and depth 3m is 144m^3 .
Calculate its surface area.

Find the volume of a square based pyramid which has a base of length 10 cm and surface area of 240cm^2

A hemispherical bowl of radius 6 cm has the same volume as a cone of perpendicular height 27cm. Calculate the surface area of the cone.

End of Summer Pack